

**u700 PRODUCTS**  
**instructions**

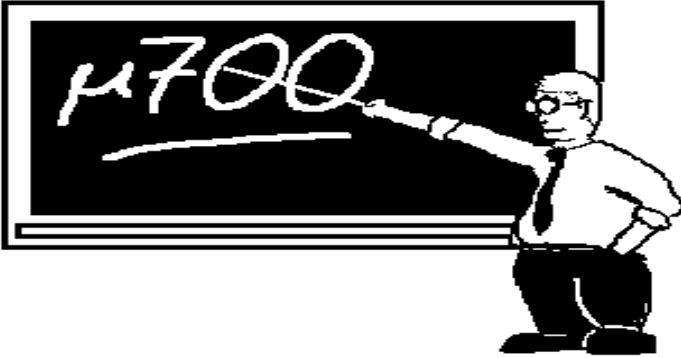

file: \u700\product\instruct\lm004.wri (Microsoft **Write** format)

# **754D-LM4**

## 754D-LM4 Connection Diagram

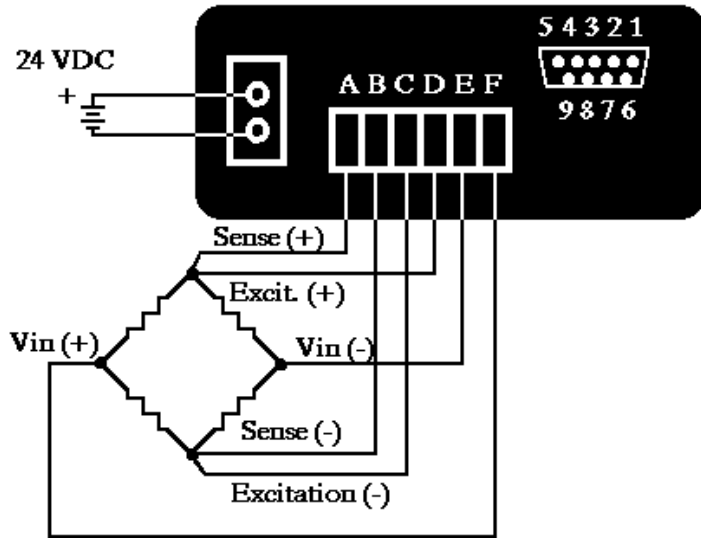

**NOTE:** When using a 6-wire transducer, wire it as shown above. When using a 4-wire transducer (without Sense (+) and Sense (-) wires), you must add one jumper wire that connects pin (A) to pin (D) and another jumper that connects pin (B) to pin (C).

The connections are listed below:

### 2-pin Barrier Block

(top) +24 V DC

(bottom) Ground

### 6-pin Screw Terminals

(A) Sense (+)

(B) Sense (-)

(C) Excitation (-)

(D) Excitation (+)

(E) Vin (-)

(F) Vin (+)

### 9-pin D-sub

- (1) Output #1 - Tare Complete, begin fill
- (2) Output #2 - Preset #1 reached, slow fill
- (3) Output #3 - Preset #1 reached, end fill
- (4) Output #4 - Not used
- (5) Signal Ground
- (6) Input #1 - Tare Now
- (7) Input #2 - Disable Outputs
- (8) Input #3 - Not used
- (9) Input #4 - Not used

## 754D-LM4 Inputs and Outputs

Output #1 - Output #4 are open collector transistors that conduct to ground (pin (5)) when energized. These outputs are rated at 50 mA when conducting and 30 volts when not conducting.

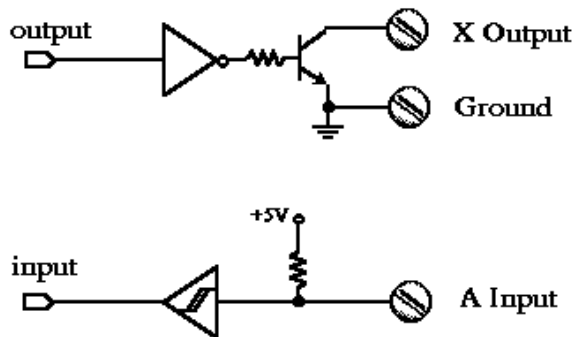

### Fill by Weight Operating Sequence

When Input #1 is energized (contacted to signal ground), the instrument uses the next measurement as a tare. This input may be from a sensor detecting the arrival of a container at the filling point.

Output #1 is energized when the tare is complete, a signal that filling may begin.

This instrument is implemented for single stage filling. Preset #1 determines the fill weight.

Output 2 is ON (output transistor energized) if Weight is equal to or greater than the Programmed Setpoint. Output 2 is latched; ie, once the weight reaches the setpoint, the output stays on until the cycle is completed by the container being removed (Input #1 becomes de-energized).

Note: Input #1 should be energized as long as a container is in place.

Alternate implementations allow multi-stage filling. For example, all three outputs may be used for 3-stage filling. Once Output #4 is energized, all outputs remain in their state until input #1 is de-energized. Input #1 de-energized may be from a sensor detecting that the filled container has been removed from the filling point.

Contact Scanning Devices for alternative implementations.

## 754D-LM4 PROGRAMMING INSTRUCTIONS OUTLINE

In general, several programmable parameters that are used by the 754D-LM4 will need to be adjusted to suit your particular application. The simple procedures below describe how to customize control setpoints, engineering units for the display, tare or "zero" weights, and the decimal point position.

To enter the programming mode, press the **PR(1)** key. You will see a Main Menu of five items ("12345"). To select one of the menu items, press the corresponding key. For example, to select Main Menu Item #2, press **SET(2)**. The procedures for each of these menu items is outlined below.

### MAIN MENU ITEM #1: Programming the Control Setpoints

The display will show a "PS" in the lower left corner to prompt you for the 3-digit password. Use the keys to enter your password: **4-1-3**. (Press  $\vee$  (**4**), **PR(1)**,  $\wedge$  (**3**)). If you make a mistake or delay more than 30 seconds, the unit will return to normal operation and you will have to try again.

After successfully entering the password, you will see a "1" in the lower left corner of the display and the current value of Setpoint #1. Use the keys to modify the value:

**PR(1)** key -- Press this key to escape the procedure without making any changes. When you have completed programming all the digits, the new value of the parameter will remain in the display (with no digits blinking) awaiting verification. If you press the key at this time, the unit will allow you to make additional changes on the value.

**SET(2)** key -- Press this key to advance programming control from the blinking digit to the next digit, from left to right. When you have completed programming all the digits, the new value of the parameter will remain in the display (with no digits blinking) awaiting verification. If you press this key at this time, the unit will store the new value in memory, and move programming control to the next parameter.

$\wedge$  (**3**) key -- Press this key to increment (increase by 1) the value of the blinking digit.

$\vee$  (**4**) key -- Press this key to decrement (decrease by 1) the value of the blinking digit.

**DP(5)** key -- Press this key to toggle a decimal point after the blinking digit.

After programming Setpoint #1, you will see a "2" in the lower left corner of the display and the current value of Setpoint #2. Use the keys as described above to modify the value. Setpoints 3 and 4 follow sequentially.

Note: your controller may not implement all setpoints. Contact Scanning Devices if you need more information.

### MAIN MENU ITEM #2: Calibrating the Unit

The display will show a "PS" in the lower left corner to prompt you for the 3-digit password. Use the keys to enter your password: **4-1-3**. (Press  $\vee$  (**4**), **PR(1)**,  $\wedge$  (**3**)). If you make a mistake or delay more than 30 seconds, the unit will return to normal operation and you will have to try again.

After successfully entering the password, you will see another menu, the Calibration Menu, with three items ("12 5"). Use the **PR(1)**, **SET(2)**, or **DP(5)** key to select one of these:

#### CALIBRATION MENU ITEM #1: Using a Known Weight

This procedure is used if you are calibrating your unit with a known weight or force that can be applied to the transducer.

A "0" will appear in the lower left corner of the display. Apply any tare weight or force to the transducer, not including the known weight. Typically, this includes the weight of a platform or container on the load cell. Press the SET(2) key. (You may press the PR(1) key to quit.)

A "1" will appear in the lower left corner of the display. Apply the known weight or force to the transducer in addition to the tare weight used in the previous step. Press the SET(2) key. (You may press the PR(1) key to quit.)

A "2" will appear in the lower left corner of the display, along with the number 0.0000. Use the keys as described below to set the number to the value of the known weight that you used. For example, if you used a 25.6 lb object, set the value to 25.6000.

**PR(1)** key -- Press this key to escape the procedure without making any changes. When you have completed programming all the digits, the new value of the parameter will remain in the display (with no digits blinking) awaiting verification. If you press the key at this time, the unit will allow you to make additional changes on the value.

**SET(2)** key -- Press this key to advance programming control from the blinking digit to the next digit, from left to right. When you have completed programming all the digits, the new value of the parameter will remain in the display (with no digits blinking) awaiting verification. If you press this key at this time, the unit will store the new value in memory, and move programming control to the next parameter.

**^ (3)** key -- Press this key to increment (increase by 1) the value of the blinking digit.

**v (4)** key -- Press this key to decrement (decrease by 1) the value of the blinking digit.

**DP(5)** key -- Press this key to toggle a decimal point after the blinking digit.

## **CALIBRATION MENU ITEM #2: Using a Full Scale Specification**

This procedure is used if you are calibrating your unit with a value that is specified by the transducer manufacturer. The unit is factory calibrated to display 1.0000 when a full scale input (20 mV) is applied to the signal terminals. Often, the transducer manufacturer will specify their product's force-voltage relationship at the full scale value; this number may be used to calibrate the unit. For example, if you use a load cell that is specified to produce a 20.0 mV signal with a 5.02 lb load applied, enter 5.02000 for this value.

A "2" will appear in the lower left corner of the display, along with the number 1.0000. Use the keys as described below to set the number to the full scale value described above.

**PR(1)** key -- Press this key to escape the procedure without making any changes. When you have completed programming all the digits, the new value of the parameter will remain in the display (with no digits blinking) awaiting verification. If you press the key at this time, the unit will allow you to make additional changes on the value.

**SET(2)** key -- Press this key to advance programming control from the blinking digit to the next digit, from left to right. When you have completed programming all the digits, the new value of the parameter will remain in the display (with no digits blinking) awaiting verification. If you press this key at this time, the unit will store the new value in memory, and move programming control to the next parameter.

∧ (3) key -- Press this key to increment (increase by 1) the value of the blinking digit.

∨ (4) key -- Press this key to decrement (decrease by 1) the value of the blinking digit.

DP(5) key -- Press this key to toggle a decimal point after the blinking digit.

**CALIBRATION MENU ITEM #5: Quit**

Press this to quit the programming routine.

### **MAIN MENU ITEM #3: Selecting the Digital Filter Value**

The display will show the current value of the Digital Filter variable. Possible values are 1, 2, 4, 8. The value is the number of samples included in a moving average of samples which is used to calculate weight. For precision measurements, use a larger value. For high speed measurements, use a smaller number.

Use the <UP> and <DOWN> buttons to adjust the Operating Mode.

Use the <SET> key to store the mode and exit the procedure.

### **MAIN MENU ITEM #4: Zeroing the display**

Selecting this item will zero the display with the current load applied.

### **MAIN MENU ITEM #5: Quit**

Press this to quit the programming routine.

## 754D-LM4 TROUBLESHOOTING

If your unit does not appear to work properly, the following steps may help you determine the source of the problem. As always, feel free to contact the Engineering Department at Scanning Devices if you need assistance. The toll free number is:

**1 800 323 3347**

**PROBLEM: The unit does not appear to be powered up; no characters on the front panel display are illuminated.**

- (1) Check the wiring to the 2-pin Barrier Block on the back panel of the unit. The top terminal must be 24 V DC, positive with respect to the bottom terminal.
- (2) If you have a voltmeter, place the (+) lead of the meter on the top terminal of the 2-pin Barrier Block and the (-) lead on the bottom terminal. The meter should read approximately 24 V DC . If it does, proceed to the next step. If it does not, check your power supply; it may be defective.
- (3) Contact Scanning Devices; the unit may be damaged.

**PROBLEM: The unit does not appear to be measuring properly.**

- (1) Check the wiring to the 2-pin Barrier Block on the back panel of the unit. The top terminal must be 24 V DC, positive with respect to the bottom terminal.
- (2) If you have a voltmeter, place the (+) lead of the meter on the top terminal of the 2-pin Barrier Block and the (-) lead on the bottom terminal. The meter should read at least 15 V. If it is lower than this, the internal circuitry will not measure properly; another supply must be used.
- (3) Check the wiring to the 6-pin Screw Terminals on the back panel. If you are using a 6-wire transducer, it must be wired as shown in the figure on the first page. If you are using a 4-wire transducer, you will notice that there are no "sense" wires. Therefore, the Sense (+) and Sense (-) terminals must be connected to their corresponding excitation terminals (Excitation (+) and Excitation (-), respectively). To do this, add one jumper from pin (A) to pin (D) and another jumper from pin (B) to pin (C).
- (4) Use a voltmeter to check the transducer excitation. Place the (+) lead of the meter on pin (D) and the (-) lead on pin (C). The meter should read 10 V DC. If it does not, remove the transducer and repeat the experiment. If the meter reads 10 V DC only when the transducer is removed, the transducer may be damaged or wired incorrectly. If the meter still does not read 10 V even with the transducer removed, contact Scanning Devices; the unit may be damaged.
- (5) Use a voltmeter to check the "sense" terminals. Place the (+) lead of the meter on pin (A) and the (-) lead on pin (B). Again, the meter should read 10 V DC. If it does not, check step (3) above to make sure that pin (A) is connected to pin (D) and that pin (B) is connected to pin (C).
- (6) Use a voltmeter to check the transducer signal terminals. Place the (+) lead of the meter on pin (E) and the (-) lead on pin (C). The meter should read approximately 5 V DC. Place the (+) lead on pin (F). Again, the meter should read 5 V DC. If it does not, the transducer may be damaged.



**PROBLEM: The unit shows "Ex" "-----" in the display, either intermittently or constantly.**

The unit has several error codes that are used to indicate certain conditions that occur during operation. If one of these conditions occur, the display will show six hyphens ("-----") and an error code in the lower left corner ("E0" through "E4"). Some of the error conditions will require the user to press the **SET(2)** key to restore the unit to normal operation, while others will be cleared automatically. Although not all of them are particularly significant to the user, they are listed below for reference:

Error E0 -- This error can occur during the calibration routine (Programming MAIN MENU ITEM #2). It indicates that a problem occurred while trying to measure the known weight. Usually, it means that the unit is unable to differentiate between the first measurement (platform, etc.) and the second measurement (platform, etc. **plus** the known weight). To clear the error condition, press and release the **SET(2)** key.

Error E1 -- This is an internal math error which will, in general, never occur. The error condition will clear automatically.

Error E2 -- Not used in this version.

Error E3 -- This error will occur if the value of the measurement is too large to fit in the display. If it occurs, try moving the decimal point to the right (using Programming MAIN MENU ITEM #3) to allow larger numbers to be displayed. The error condition will clear automatically.

Error E4 -- This error will occur if the transducer input signal exceeds the allowable range (20 mV). If it occurs during normal operation, it will clear itself as soon as the input signal falls back within the specified range. If it occurs during the calibration routine (Programming MAIN MENU ITEM #2) or the "zeroing" routine (Programming MAIN MENU ITEM #4), the error must be cleared by pressing and releasing the **SET(2)** key.